

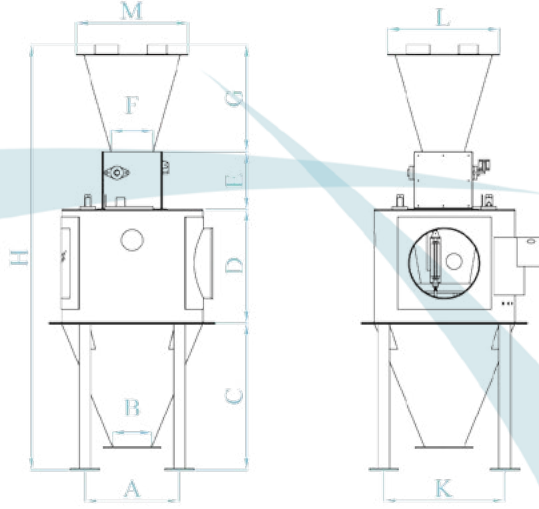

RANDIMAN
KANTARI
EXTRACTION RATE
SCALE

Randıman Kantarı / Extraction Rate Scale

Teknik Bilgiler ve Montajları Dimensions & Technical Data



Ölçüler / Dimensions (mm)

MODEL TYPE	A	BxB1	C	D	E	F	G	H	K	L	M
GD-RK-30	715	200	708	592	300	220	555	2155	715	500	500
GD-RK-60	765	200	708	692	300	220	555	2255	765	500	500
GD-RK-100	835	200	810	765	300	220	555	2430	835	500	500
GD-RK-250	1119	300	1158	935	360	280	900	3353	1119	1000	1000
GD-RK-500	1260	400	1560	1240	660	465	809	4265	1260	1060	1060
GD-RK-700	1875	510	1550	1000	425	810	1200	4180	1100	1200	1205
GD-RK-1500	1860	605	1860	1450	425	805	1660	5390	1350	1525	1525
GD-RK-2000	2160	605	1900	1450	425	805	2200	5980	2160	2000	2000

Ölçüler / Technical Data

MODEL TYPE	Ürün / Product Buğday-Un-Kepek Wheat - Flour - Bran	Kapasite Bin Capacity	Kapasite Extraction Capacity			Aspirasyon Aspiration (m ³)	Hava İhtiyacı Air Required (m ³ /bar)	Ağırlık Weight (kg)
			Buğday	Un	Kepek			
GD-RK-30	Buğday-Un-Kepek	30	2-5	0-3	0-1,5	8	5-6	350
GD-RK-60	Buğday-Un-Kepek	60	3-10	1-6	1-3	10	5-6	450
GD-RK-100	Buğday-Un-Kepek	100	5-25	4-15	2-6	12	5-6	525
GD-RK-250	Buğday-Un-Kepek	250	10-50	6-30	3-15	12	5-6	525
GD-RK-500	Buğday	320	50-100	-	-	16	5-6	675
GD-RK-700	Buğday	700	100-150	-	-	20	5-6	720
GD-RK-1500	Buğday	1500	150-300	-	-	28	5-6	810
GD-RK-2000	Buğday	2000	350-450	-	-	36	8-10	1100

EXTRACTION RATE SCALE

The extraction rate control unit is used for weighing products such as wheat, flour, bran etc. It provides continuous control of product yield rates. The extraction rate scales operation starts with the product filling the measuring container. The product enters the container under control by means of the flap which controls access to the container. The measuring process is carried out, and the stabilization time controlled by load cells located at three points on the measuring-container. When the required level is reached the upper flap is closed. On completion of the measuring process, the measured product is released to the line via the opening flaps located under the container. Flaps allowing product to be discharged to the bunker, and the bunker lids which empty the bunker all work pneumatically. Also, there are covers positioned on the scales component and both sides of the upper bunker in order to facilitate the cleaning of the extraction rate weighing machine. These covers are sufficiently large to allow cleaning and maintenance, and they are also fitted with gaskets in order to provide leak proofing when closed.

EXTRACTION RATE SCALE

The extraction rate scale is used for weighing products such as wheat, flour, bran... It provides continuous control of product's yield rates. The extraction rate scale operation starts with the product filling the measuring container. The product enters the container under control by means of the flap which controls access to the container. The measuring process is carried out, and the stabilization time controlled by load cells located at three points on the measuring container. When the required level is reached, the upper flap is closed. On completion of the measuring process, the measured product is released to the line via the opening flaps located under the container. Both the flaps which allow the product to be discharged to the bunker, and the bunker lids which empty the bunker, work pneumatically. Also, there are covers positioned on the scale's component and on both sides of the upper bunker in order to facilitate the cleaning of the extraction rate weighing machine. These covers are sufficiently large to allow easy cleaning and maintenance. They are also fitted with gaskets in order to prevent leaking when closed.